

ENGINEERING

Timing Belt Drives

Tolerances & Specifications

Timing Pulleys - Timing Pulley Stock
Flanges - Belts

Table of Contents

TOLERANCES & SPECIFICATIONS	E2
Timing pulleys, timing pulley stock, flanges	
TOLERANCES & SPECIFICATIONS	E3
Belts	
CENTER DISTANCE CALCULATION	E6
STANDARD CALCULATIONS	E7
SPECIFICATION FOR DRIVES USING	E8
SYNCHRONOUS BELTS	
SYNCHRONOUS BELTS	E13
BELT PROFILE AND PITCH SELECTION	E18
BELT MATERIALS AND CONSTRUCTION	E26
TRUMOTION BELTS	E27
TENSIONERS	E28

TOLERANCES & SPECIFICATIONS

Timing pulleys • timing pulley stock • flanges

TIMING PULLEYS O.D. TOLERANCES

.080" PITCH	+ .003	- .000
.0816" PITCH (40 D.P.)	+ .000	- .003

2mm, 3mm, 5mm, 1/5" PITCH TO 1-1/4" PITCH

0" – 1.000" O.D.	+ .002	- .000
1.001" – 2.000" O.D.	+ .003	- .000
2.001" – 4.000" O.D.	+ .004	- .000
4.001" – 7.000" O.D.	+ .005	- .000
7.001" – 12.000" O.D.	+ .006	- .000
12.001" – 20.000" O.D.	+ .007	- .000
20.000" AND UP O.D.	+ .008	- .000

BORE TOLERANCES

0" – 1.000"	+ .001	- .000
1.001" – 2.000"	+ .0015	- .000
2.001" – 3.000"	+ .002	- .000
3.001" AND UP	+ .0025	- .000

ECCENTRICITY TOLERANCE

(PULLEY BORE TO O.D.)

0" – 8.000"	.004 T.I.R.
8.000" AND UP	.0005 T.I.R. PER INCH OF PULLEY DIA. (NOT TO EXCEED O.D. TOLERANCE)

LATERAL RUN OUT TOLERANCE

.001 T.I.R. PER INCH OF PULLEY DIA. (.020 MAX.)

TIMING PULLEY STOCK O.D. TOLERANCES

.0816" PITCH (40D.P.) +.000 -.003

2mm, 3mm, 5mm, .080" PITCH, 1/5" TO 1-1/4" PITCH

0" – 1.000" O.D.	+ .002	- .000
1.001" – 2.000" O.D.	+ .003	- .000
2.001" – 4.000" O.D.	+ .004	- .000
4.000" – 7.000" O.D.	+ .005	- .000

FLANGES TOLERANCES

PITCH	OVERALL FORMED		
	I.D.	O.D.	THICKNESS
.080	±.003	±.015	±.010
.0816 (40 D.P.)	±.003	±.015	±.010
2mm	±.003	±.015	±.010
3mm	±.003	±.015	±.010
5mm	±.003	±.015	±.010
1/5"	±.003	±.015	±.010
3/8"	±.005	±.015	±.010



TOLERANCES & SPECIFICATIONS

BELTS

.080" PITCH

BLACK NEOPRENE
FIBERGLASS CORD

BREAKING STRENGTH

53 LBS PER 1/8" OF BELT WIDTH

TEMPERATURE RANGE

-30°F TO 185°F

WIDTH TOLERANCE

STANDARD SLIT TOLERANCE IS $\pm 1/64$ "

.080" PITCH

ORANGE URETHANE
POLYESTER CORD

BREAKING STRENGTH

520 LBS. PER INCH OF WIDTH

TEMPERATURE RANGE

0°F TO 180°F

LENGTH TOLERANCE

CENTER DISTANCE TOLERANCE $\pm .020$ "

WIDTH TOLERANCE

$\pm .020$ " FOR BELTS 1/16" - 4" WIDE

.080" PITCH

GRAY URETHANE
KEVLAR CORD

BREAKING STRENGTH

1050 LBS. PER INCH OF WIDTH

TEMPERATURE RANGE

0°F TO 180°F

LENGTH TOLERANCE

CENTER DISTANCE TOLERANCE $\pm .020$ "

WIDTH TOLERANCE

$\pm .020$ " FOR BELTS 1/16" - 4" WIDE

.080" PITCH

BLACK POLYURETHANE
POLYESTER CORD

BREAKING STRENGTH

1000 LBS. PER INCH OF WIDTH IN
ENDLESS FORM

TEMPERATURE RANGE

-40°F TO 180°F

LENGTH TOLERANCE

$\pm .016$ " TO $\pm .026$ "

WIDTH TOLERANCE

BELT SLIT WIDTH IS $\pm 1/64$ "

NOMINAL MINIMUM BELT WIDTH IS 1/8"

.0816" PITCH (40 D.P.)

YELLOW URETHANE
POLYESTER CORD

BREAKING STRENGTH

520 LBS. PER INCH OF WIDTH

TEMPERATURE RANGE

0°F TO 180°F

LENGTH TOLERANCE

CENTER DISTANCE TOLERANCE $\pm .020$ "

WIDTH TOLERANCE

$\pm .020$ " FOR BELTS 1/16" - 4" WIDE

.0816" PITCH (40 D.P.)

BLACK URETHANE
KEVLAR CORD

BREAKING STRENGTH

1050 LBS. PER INCH OF WIDTH

TEMPERATURE RANGE

0°F TO 180°F

LENGTH TOLERANCE

CENTER DISTANCE TOLERANCE $\pm .020$ "

WIDTH TOLERANCE

$\pm .020$ " FOR BELTS 1/16" - 4" WIDE

TOLERANCES & SPECIFICATIONS

BELTS

.0816" PITCH (40 D.P.)

BLACK POLYURETHANE
POLYESTER CORD

BREAKING STRENGTH

400 LBS. PER INCH OF WIDTH IN
ENDLESS FORM

TEMPERATURE RANGE

-40°F TO 160°F

LENGTH TOLERANCE

± .020" ON CENTER DISTANCE

WIDTH TOLERANCE

BELT SLIT WIDTH IS ± 1/64"
NOMINAL MINIMUM BELT WIDTH IS 1/8"

1/5" PITCH

BLACK POLYURETHANE
KEVLAR CORD

BREAKING STRENGTH

1200 LBS. PER INCH OF WIDTH IN
ENDLESS FORM

TEMPERATURE RANGE

-40° F TO 212° F

LENGTH TOLERANCE

± .016" TO ± .026"

WIDTH TOLERANCE

BELT SLIT WIDTH IS ± 1/64"
NOMINAL MINIMUM BELT WIDTH IS 1/8"

1/5" PITCH

BLACK URETHANE
POLYESTER CORD

BREAKING STRENGTH

630 LBS. PER INCH OF WIDTH

TEMPERATURE RANGE

0°F TO 180°F

LENGTH TOLERANCE

CENTER DISTANCE TOLERANCE ± .020"

WIDTH TOLERANCE

± .020" FOR BELTS 1/16"– 4" WIDE

3/8" PITCH

BLACK URETHANE
POLYESTER CORD

BREAKING STRENGTH

630 LBS. PER INCH OF WIDTH

TEMPERATURE RANGE

0°F TO 180°F

LENGTH TOLERANCE

CENTER DISTANCE TOLERANCE ±.020"

WIDTH TOLERANCE

± .020" FOR BELTS 1/16"– 4" WIDE

1/5" PITCH

BLACK URETHANE
KEVLAR CORD

BREAKING STRENGTH

2500 LBS. PER INCH OF WIDTH

TEMPERATURE RANGE

0°F TO 180°F

LENGTH TOLERANCE

CENTER DISTANCE TOLERANCE ± .020"

WIDTH TOLERANCE

± .020" FOR BELTS 1/16"– 4" WIDE

3/8" PITCH

BLACK URETHANE
KEVLAR CORD

BREAKING STRENGTH

3000 LBS. PER INCH OF WIDTH

TEMPERATURE RANGE

0°F TO 180°F

LENGTH TOLERANCE

CENTER DISTANCE TOLERANCE ± .020"

WIDTH TOLERANCE

± .020" FOR BELTS 1/16"– 4" WIDE



TOLERANCES & SPECIFICATIONS

BELTS

1/5"- 3/8" PITCH

BLACK NEOPRENE FIBREGLASS CORD
TEMPERATURE RANGE -30° F TO 185° F

STANDARD TIMING BELT WIDTH TOLERANCES

(FOR NEOPRENE BELTS 1/5"
AND 3/8" PITCH)*

BELT WIDTH IN.	WIDTH TOLERANCE ON BELT LENGTHS 0" TO 33"	WIDTH TOLERANCE ON BELT LENGTHS OVER 33" TO 66"	WIDTH TOLERANCE ON BELT LENGTHS OVER 66"
1/8 TO 7/16	+1/64 -1/32	+1/64 -1/32	
OVER 7/16 TO 1-1/2	+1/32 -1/32	+1/32 -3/64	+1/32 -3/64
OVER 1-1/2 TO 2	+1/32 -3/64	+3/64 -3/64	+3/64 -1/16
OVER 2 TO 2-1/2	+3/64 -3/64	+3/64 -1/16	+1/16 -1/16
OVER 2-1/2 TO 3	+3/64 -1/16	+1/16 -1/16	+1/16 -5/64
OVER 3 TO 4	+1/16 -1/16	+1/16 -5/64	+5/64 -5/64
OVER 4	+3/32 -3/32	+3/32 -7/64	+3/32 -1/8

*Over 1/2 in pitch for belts up to and including 4 inches wide, tolerance= ± 3/16 in. for belts over 4 inches wide, tolerance +3/16 – 1/4

STANDARD NEOPRENE TIMING BELT CENTER-DISTANCE TOLERANCES

BELT LENGTH IN.	*TOLERANCE CENTER-DISTANCE IN.
5 TO 10	±.008
OVER 10 TO 15	±.009
OVER 15 TO 20	±.010
OVER 20 TO 30	±.012
OVER 30 TO 40	±.013
OVER 40 TO 50	±.015
OVER 50 TO 60	±.016
OVER 60 TO 70	±.017
OVER 70	ON APPLICATION ADD .001" FOR EVERY 10" SPREAD

*Tolerances are for reference only. Belts measured on 20 groove pulleys under allowable working tensions.

TWIN POWER BELTS 1/5"- 3/8" PITCH

BLACK NEOPRENE FIBREGLASS CORD
TEMPERATURE RANGE -30° F TO 185° F

TWIN POWER TOLERANCES

Since twin power belts are manufactured and cut to the required width by the same method as standard belts, the same manufacturing tolerances apply, except for the thickness and length tolerances which are shown in the following tables.

BELT THICKNESS TOLERANCES

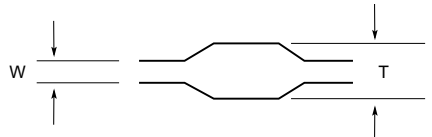

PITCH	T (IN.)	W (IN.)
1/5-INCH (XL)	.120 ± .006	.020 ± .004
3/8-INCH (L)	.180 ± .006	.030 ± .004

CENTER-DISTANCE TOLERANCES

BELT LENGTH IN.	*TOLERANCE CENTER-DISTANCE IN.
15 TO 20	±.020
OVER 20 TO 30	±.024
OVER 30 TO 40	±.026
OVER 40 TO 50	±.030
OVER 50 TO 60	±.032
OVER 60 TO 70	±.034
OVER 70	(REFER TO FACTORY)

MILLIMETER BELTS

3 MM-5 MM
BLACK NEOPRENE FIBREGLASS CORD
TEMPERATURE RANGE -30° F TO 185° F

CENTER DISTANCE CALCULATION

(Design software such as York Industries free "DriveWorks" program can be used instead of this table)

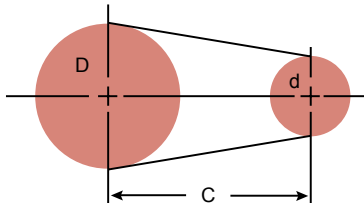

BL = belt length
 D = larger sprocket pitch diameter
 d = Smaller sprocket pitch diameter
 C = Center distance

Equations

$$A = \frac{BL}{2} - .7855 (D+d) \quad B = \frac{A}{(D-d)} \quad C = \frac{A}{F^*}$$

*Correction Factor F is given in the table below opposite the appropriate value of B as calculated using the above equations.

Correction Factor (F) Table

B	F	B	F	B	F	B	F	B	F	B	F	B	F
0.7998	1.4286	0.8335	1.3459	0.8826	1.2723	0.9558	1.2063	1.072	1.1468	1.278	1.0929	1.769	1.0438
0.8005	1.4265	0.8344	1.3441	0.8839	1.2706	0.9579	1.2048	1.076	1.1455	1.285	1.0917	1.789	1.0428
0.8011	1.4245	0.8354	1.3423	0.8853	1.2690	0.9601	1.2034	1.079	1.1442	1.291	1.0905	1.810	1.0417
0.8018	1.4225	0.8363	1.3405	0.8867	1.2674	0.9622	1.2019	1.082	1.1429	1.298	1.0893	1.832	1.0406
0.8024	1.4205	0.8372	1.3387	0.8882	1.2658	0.9644	1.2005	1.086	1.1416	1.305	1.0881	1.855	1.0395
0.8031	1.4184	0.8381	1.3369	0.8897	1.2642	0.9666	1.1990	1.090	1.1403	1.312	1.0870	1.879	1.0384
0.8037	1.4164	0.8391	1.3351	0.8911	1.2626	0.9687	1.1976	1.093	1.1390	1.320	1.0858	1.904	1.0373
0.8044	1.4144	0.8402	1.3333	0.8925	1.2610	0.9710	1.1962	1.097	1.1377	1.327	1.0846	1.930	1.0363
0.8051	1.4122	0.8412	1.3316	0.8940	1.2594	0.9733	1.1947	1.101	1.1364	1.335	1.0834	1.956	1.0352
0.8058	1.4104	0.8422	1.3298	0.8955	1.2579	0.9757	1.1933	1.105	1.1351	1.343	1.0823	1.984	1.0341
0.8066	1.4085	0.8432	1.3280	0.8971	1.2563	0.9780	1.1919	1.109	1.1338	1.351	1.0811	2.014	1.0331
0.8073	1.4065	0.8442	1.3263	0.8985	1.2547	0.9803	1.1905	1.113	1.1325	1.360	1.0799	2.045	1.0320
0.8080	1.4045	0.8452	1.3245	0.9000	1.2531	0.9828	1.1891	1.117	1.1312	1.368	1.0787	2.078	1.0309
0.8087	1.4025	0.8463	1.3228	0.9015	1.2516	0.9851	1.1876	1.121	1.1299	1.377	1.0776	2.112	1.0299
0.8094	1.4006	0.8473	1.3210	0.9031	1.2500	0.9875	1.1862	1.125	1.1287	1.386	1.0764	2.148	1.0288
0.8101	1.3986	0.8484	1.3193	0.9047	1.2484	0.9900	1.1848	1.129	1.1274	1.395	1.0753	2.186	1.0277
0.8108	1.3966	0.8495	1.3175	0.9063	1.2469	0.9924	1.1834	1.133	1.1261	1.404	1.0741	2.227	1.0267
0.8116	1.3947	0.8505	1.3158	0.9079	1.2453	0.9949	1.1820	1.138	1.1249	1.413	1.0730	2.270	1.0256
0.8123	1.3928	0.8517	1.3141	0.9095	1.2438	0.9974	1.1806	1.142	1.1236	1.423	1.0718	2.315	1.0246
0.8131	1.3908	0.8529	1.3123	0.9112	1.2422	1.000	1.1792	1.146	1.1223	1.432	1.0707	2.362	1.0235
0.8139	1.3889	0.8540	1.3106	0.9128	1.2407	1.002	1.1779	1.150	1.1211	1.442	1.0695	2.414	1.0225
0.8147	1.3870	0.8551	1.3089	0.9145	1.2392	1.005	1.1765	1.155	1.1198	1.453	1.0684	2.469	1.0215
0.8155	1.3850	0.8563	1.3072	0.9161	1.2376	1.008	1.1751	1.160	1.1186	1.463	1.0672	2.529	1.0204
0.8162	1.3831	0.8574	1.3055	0.9178	1.2361	1.011	1.1737	1.164	1.1173	1.474	1.0661	2.594	1.0194
0.8170	1.3812	0.8585	1.3038	0.9196	1.2346	1.013	1.1723	1.169	1.1161	1.485	1.0650	2.664	1.0183
0.8178	1.3793	0.8597	1.3021	0.9214	1.2330	1.016	1.1710	1.174	1.1148	1.497	1.0638	2.739	1.0173
0.8186	1.3774	0.8609	1.3004	0.9231	1.2315	1.019	1.1696	1.178	1.1136	1.509	1.0627	2.823	1.0163
0.8194	1.3755	0.8621	1.2987	0.9248	1.2300	1.021	1.1682	1.183	1.1123	1.521	1.0616	2.913	1.0152
0.8202	1.3736	0.8633	1.2970	0.9265	1.2285	1.024	1.1669	1.189	1.1111	1.533	1.0604	3.013	1.0142
0.8211	1.3717	0.8645	1.2953	0.9284	1.2270	1.027	1.1655	1.194	1.1099	1.546	1.0593	3.125	1.0132
0.8220	1.3699	0.8657	1.2937	0.9302	1.2255	1.030	1.1641	1.199	1.1086	1.558	1.0582	3.247	1.0121
0.8228	1.3680	0.8669	1.2920	0.9320	1.2240	1.033	1.1628	1.205	1.1074	1.571	1.0571	3.392	1.0111
0.8237	1.3661	0.8682	1.2903	0.9339	1.2225	1.036	1.1614	1.210	1.1062	1.585	1.0560	3.556	1.0101
0.8246	1.3643	0.8695	1.2887	0.9358	1.2210	1.039	1.1601	1.216	1.1050	1.599	1.0549	3.746	1.0091
0.8254	1.3624	0.8707	1.2870	0.9378	1.2195	1.042	1.1587	1.222	1.1038	1.614	1.0537	3.971	1.0081
0.8263	1.3605	0.8719	1.2853	0.9397	1.2180	1.045	1.1574	1.227	1.1025	1.629	1.0526	4.241	1.0070
0.8272	1.3587	0.8732	1.2837	0.9416	1.2165	1.049	1.1561	1.233	1.1013	1.645	1.0515	4.580	1.0060
0.8280	1.3569	0.8745	1.2821	0.9435	1.2151	1.052	1.1547	1.239	1.1001	1.661	1.0504	5.020	1.0050
0.8289	1.3550	0.8759	1.2804	0.9455	1.2136	1.055	1.1534	1.245	1.0989	1.678	1.0493	5.600	1.0040
0.8298	1.3532	0.8772	1.2788	0.9475	1.2121	1.059	1.1521	1.252	1.0977	1.695	1.0482	6.465	1.0030
0.8307	1.3514	0.8785	1.2771	0.9495	1.2107	1.062	1.1507	1.258	1.0965	1.713	1.0471	7.914	1.0020
0.8316	1.3495	0.8799	1.2755	0.9516	1.2092	1.065	1.1494	1.265	1.0953	1.731	1.0460	11.186	1.0010
0.8326	1.3477	0.8812	1.2739	0.9537	1.2077	1.069	1.1481	1.271	1.0941	1.749	1.0449	AND UP	1.0000



York can supply modified stock pulleys or complete specials upon request
 email: support@york-ind.com web: www.york-ind.com

STANDARD CALCULATIONS

REQUIRED	GIVEN	FORMULA
Speed ratio (R)	Shaft speeds (rpm)	$R = \frac{\text{rpm (faster shaft speed)}}{\text{rpm (slower shaft speed)}}$
	Pulley diameters (D & d)	$R = \frac{D \text{ (larger pulley diameter)}}{d \text{ (smaller pulley diameter)}}$
	Number of pulley groves (N&n)	$R = \frac{N \text{ (larger pulley groove no.)}}{n \text{ (smaller pulley groove no.)}}$
Horsepower (hp)	Torque (T) in in-lbs Shaft speed (rpm)	$hp = \frac{T \times \text{rpm}}{63,025}$
Design horsepower (Dhp)	Rated Horsepower (hp) Service factor (SF)	$Dhp = hp \times SF$
Power (kw)	Horsepower (hp)	$kw = 7457 \times hp$
Torque (T) in in – lbs.	Shaft horsepower (hp) Shaft speed (rpm)	$T = \frac{63,025 \times hp}{\text{rpm}}$
Torque (T) in N-mm	Torque (T) in in-lbs	$T = 112.98 \times T$
Peak Torque (T)	Torque (T) Service factor (SF)	$T = T \times SF$
Effective tension (Te) in pounds	Shaft horsepower (hp) Belt speed (BS)	$Te = \frac{33,000 \times hp}{BS}$
	Effective tension (Te) in Newtons	$Te = 2248 \times Te$
Effective tension (Te) in pounds	Torque (T) in in-lbs Pulley pd in inches	$Te = \frac{2 \times T}{pd}$
Effective tension (Te) in Newtons	Torque (T) in N-mm Pulley pd in mm	
Effective tension (Te) in Newtons	Effective tension (Te) in pounds	$Te = 4.4484 \times Te$
Centrifugal tension loss (Tc)	Smaller pulley pd Smaller pulley rpm Tc constant Kc	$Tc = Kc \times pd^2 \times \text{rpm}^2$
Allowable working tension (Ta)	Te, Tc & SF	$Ta = (Te + Tc) \times SF$
Service factor (SF)	Belt width Rated Ta for given belt width Calculated Te & Tc	$SF = \frac{\text{Rated } Ta}{Te + Tc}$
Belt speed (BS) in fpm	Pulley pd in inches Pulley speed in rpm	$BS = 262 \times pd \times \text{rpm}$
Belt speed (BS) in m/s	Pulley speed in mm Pulley speed in rpm	$BS = .000524 \times pd \times \text{rpm}$
Belt length (BL)	Center distance (C) Pulley diameters (D & d)	$BL = \frac{2C + (D - d)^2 + 1.57 \times (D + d)}{4C}$
Arc of contact on smaller pulley (A/Cs)	Pulley diameters (D & d) Center distance (C)	$A/Cs = 180 - \frac{(D - d) \times 60}{C}$

If TIM is less than 6, correct peak torque by value shown in table below.

Teeth in Mesh (TIM) calculations

Determine arc of contact on smaller pulley (A/Cs) using the formula in the above chart. Determine teeth in Mesh (TIM) using the formula below

$$TIM = \frac{A/Cs \times \text{Smaller pulley groove no. (n)}}{360}$$

Drop any fractional part and use only the whole number as any tooth not fully engaged can not be considered a working tooth.

Teeth in Mesh Factor Table	
TM	Design Peak Torque Multiplication Factor
5	1.2
4	1.5
3	2.0
2	Suggest alternate drive
1	Suggest alternate drive

SPECIFICATION FOR DRIVES USING SYNCHRONOUS BELTS

SCOPE.

This standard applies to those belts and pulleys intended for mechanical power transmission, and where positive indexing or synchronous type service may be required.

These specifications cover three standard belt sections which are established on the basis of belt pitch. These sections are designated MXL (0.080 inch pitch), XL (0.200 inch pitch), and L (0.375 inch pitch).

It also covers dimensions for two double sided sections: DXL (0.200 inch pitch), and DL (0.375 inch pitch).

Dimensions of synchronous belts and pulleys together with basic design data are covered in this standard.

Dimensions in customary English units are provided. This standard does not apply to automotive drives for which other standards exist.

SYNCHRONOUS BELT PULLEYS

DIAMETERS.

Table 1 lists the standard pulley diameters by belt section (pitch). Figure 1 defines the pitch, pitch diameter, outside diameter, and the pitch line differential.

WIDTHS.

The standard pulley widths are shown in Table 2 for each belt section. The nominal pulley width is specified in terms of the maximum standard belt width the pulley will accommodate. For example, only one standard nominal width is specified for the XL Belt Section - 0.38 inches. This pulley width can be used for the standard XL belt widths of 0.25 and 0.38 inches.

The actual minimum pulley width, whether flanged or unflanged, is also specified in Table 2 and shown in Figures 2 and 3.

SIZE DESIGNATION.

Pulleys are designated by the number of grooves, the belt section, and a number representing 100 times the nominal width. For example, a 30 groove L section pulley with a nominal width of 0.75 inches would be designated by the number 30L075.

GROOVE PROFILE.

The groove profile is defined as the profile formed by the generating tool rack form described in Table 3 and Figure 4. The sides of the grooves shall be free of surface defects, and the edges of all grooves shall be rounded. The flanks of the grooves shall have a finish of 125 microinches, or better.

FLANGE DIMENSIONS.

The details of suggested pulley flange design are shown in Table 4 and Figure 5.

KEYSEATS.

Keyseats in the hubs of pulleys are shown in Figure 6 and shall conform to the dimensions and tolerances given in Table 5.

BORE TOLERANCES.

Table 6 gives the bore tolerances for belt pulleys.

MISCELLANEOUS TOLERANCES.

Table 7 includes the following miscellaneous pulley tolerances: Outside Diameter, Radial Runout, Axial Runout, Pitch Accuracy.

Table 1 Standard Pulley Diameters – Inches

No. of Grooves	BELT SELECTION					
	MXL (0.080)		XL (0.200)		L (0.375)	
	Diameters		Diameters		Diameters	
	Pitch	Outside	Pitch	Outside	Pitch	Outside
10	0.255	0.235	0.637	0.617	1.194*	1.164*
12	0.306	0.286	0.764	0.744	1.432*	1.402*
14	0.357	0.337	0.891	0.871	1.671	1.641
16	0.407	0.387	1.019	0.999	1.910	1.880
18	0.458	0.438	1.146	1.126	2.149	2.119
20	0.509	0.489	1.273	1.253	2.387	2.357
22	0.560	0.540	1.401	1.381	2.626	2.596
24	0.611	0.591	1.528	1.508	2.865	2.835
26	0.662	0.642	1.656	1.636	3.104	3.074
28	0.713	0.693	1.783	1.763	3.342	3.312
30	0.764	0.744	1.910	1.890	3.581	3.551
32	0.815	0.795	2.037	2.017	3.820	3.790
34	0.866	0.846				
36	0.917	0.897	2.292	2.272	4.297	4.267
40	1.019	0.999	2.546	2.526	4.775	4.745
42	1.070	1.050	2.674	2.654		
44	1.120	1.100	2.801	2.781	5.252	5.222
48	1.222	1.202	3.056	3.036	5.730	5.700
60	1.528	1.508	3.820	3.800	7.162	7.132
72	1.833	1.813	4.584	4.564	8.594	8.564
84					10.027	9.997

*Usually not available in all widths - consult YORK

Figure 1 Pulley Dimensions

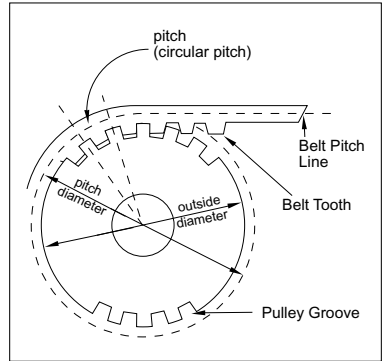

Figure 2 Flanged Pulley

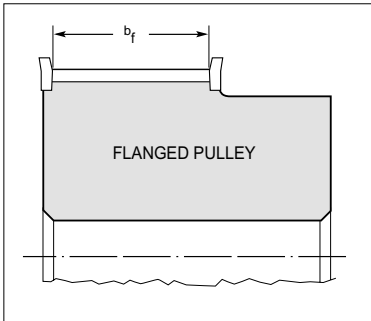

Figure 3 Unflanged Pulley

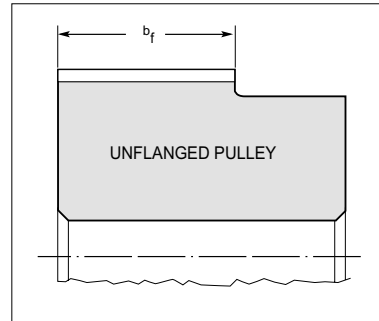

Table 2 Standard Pulley Widths – Inches (See Figures 2 & 3)

BELT SELECTION	STANDARD NOMINAL PULLEY WIDTH	STANDARD PULLEY WIDTH DESIGNATION	MINIMUM PULLEY WIDTH	
			FLANGED b_f	UNFLANGED b_f
MXL (0.080)	0.25	025	0.28	0.35
XL (0.200)	0.38	037	0.41	0.48
L (0.375)	0.50	050	0.55	0.67
	0.75	075	0.80	0.92
	1.00	100	1.05	1.17

Table 3 Pulley Generating Tool Rack Form Dimensions – Inches (See Figures 1 & 4)

BELT SELECTION	NUMBER OF GROOVES	P_b ± 0.0001	β ± 0.25 (Degrees)	h_r $+0.002$ -0.000	b_g $+0.002$ -0.000	r_1 ± 0.001	r_2 ± 0.001	2a
MXL	10 thru 23 24 & over	0.0800	56 40	0.025	0.024 0.265	0.012	0.009	0.020
XL	10 & over	0.2000	50	0.055	0.050	0.024	0.024	0.020
L	10 & over	0.3750	40	0.084	0.122	0.034	0.021	0.030

Figure 4 Pulley Generating Tool Rack Form

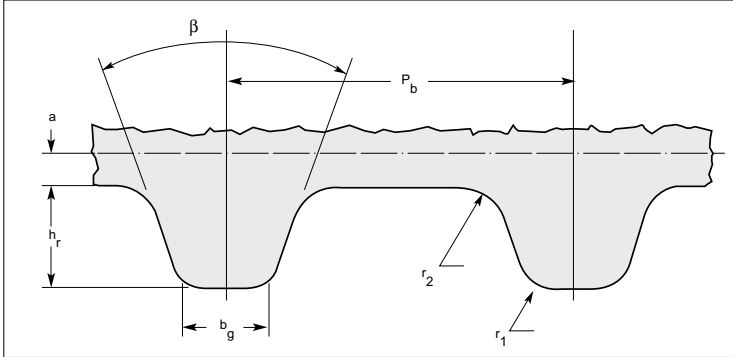

Table 4 Flange Dimensions – Inches (See Figure 5)

BELT SELECTION	MINIMUM FLANGE THICKNESS	MINIMUM FLANGE HEIGHT*
MXL (0.080)	0.023	0.020
XL (0.200)	0.029	0.040
L (0.375)	0.050	0.065

*Flange outside diameter equals pulley outside diameter plus twice flange height.

Figure 5 Flange Dimensions

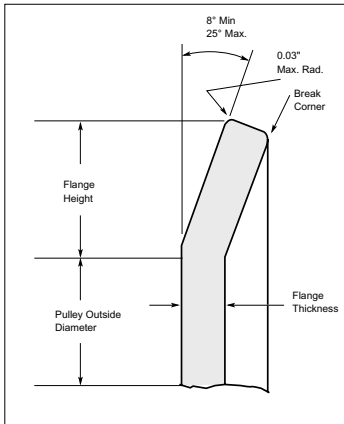
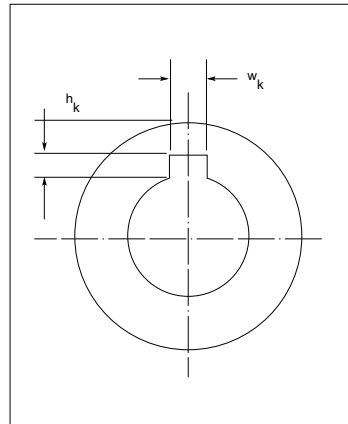

Figure 6 Keyseat Dimensions



York can supply modified stock pulleys or complete specials upon request
 email: support@york-ind.com web: www.york-ind.com

Table 5 Standard Hub Keyseat dimensions – Inches (See Figure 6)

SHAFT DIAMETER		WIDTH, w _k *	DEPTH, w _k * + 0.015 -0.000
Up Through 7/16 (0.44)		3/32 (0.094)	3/64 (0.047)
Over 7/16 (0.44) To and Incl	9/16 (0.56)	1/8 (0.125)	1/16 (0.062)
Over 9/16 (0.56) To and Incl	7/8 (0.88)	3/16 (0.188)	3/32 (0.094)
Over 7/8 (0.88) To and Incl	1-1/4 (1.25)	1/4 (0.250)	1/8 (0.125)
Over 1-1/4 (1.25) To and Incl	1-3/8 (1.38)	5/16 (0.312)	5/32 (0.156)
Over 1-3/8 (1.38) To and Incl	1-3/4 (1.75)	3/8 (0.375)	3/16 (0.188)
Over 1-3/4 (1.75) To and Incl	2-1/4 (2.25)	1/2 (0.500)	1/4 (0.250)
Over 2-1/4 (2.25) To and Incl	2-3/4 (2.75)	5/8 (0.625)	5/16 (0.312)
Over 2-3/4 (2.75) To and Incl	3-1/4 (3.25)	3/4 (0.750)	3/8 (0.375)
Over 3-1/4 (3.25) To and Incl	3-3/4 (3.75)	7/8 (0.875)	7/16 (0.438)
Over 3-3/4 (3.75) To and Incl	4-1/2 (4.50)	1 (1.000)	1/2 (0.500)
Over 4-1/2 (4.50) To and Incl	5-1/2 (5.50)	1-1/4 (1.250)	5/8 (0.625)

*Tolerance on width, w_k
 For width up through 1/2 (0.500).....+0.002, -0.000 inches
 For width over 1/2 (0.500)
 up through 1 (1.000).....+0.003, -0.000 inches
 For width over 1 (1.000).....+0.004, -0.000 inches

Table 6 Pulley Bore Tolerances — Inches

DIAMETER OF BORE	LENGTH OF BORE											
	Up Thru 0.75	Over 0.75 To And Including 1.00	Over 1.00 To And Including 1.25	Over 1.25 To And Including 1.50	Over 1.50 To And Including 2.00	Over 2.00 To And Including 2.50	Over 2.50 To And Including 3.00	Over 3.00 To And Including 3.50	Over 3.50 To And Including 4.00	Over 4.00 To And Including 4.50	Over 4.50 To And Including 5.00	Over 5.00 To And Including 6.00
Up thru 0.50	+0.0015 +0.0005	+0.0015 +0.0005	+0.0015 +0.0005	+0.0015 +0.0005	+0.0015 +0.0005							
Over 0.50 To And Including 1.00	+0.0015 +0.0005	+0.0015 +0.0005	+0.0015 +0.0005	+0.0015 +0.0005	+0.0020 +0.0005	+0.0020 +0.0005	+0.0020 +0.0005					
Over 1.00 To And Including 1.50		+0.0015 +0.0005	+0.0015 +0.0005	+0.0015 +0.0005	+0.0020 +0.0010	+0.0020 +0.0010	+0.0020 +0.0010	+0.0020 +0.0010	+0.0020 +0.0010			
Over 1.50 To And Including 2.00			+0.0020 +0.0005	+0.0020 +0.0005	+0.0025 +0.0010	+0.0025 +0.0010	+0.0025 +0.0010	+0.0025 +0.0010	+0.0025 +0.0010	+0.0030 +0.0010	+0.0030 +0.0010	+0.0030 +0.0010
Over 2.00 To And Including 2.50				+0.0020 +0.0005	+0.0025 +0.0010	+0.0025 +0.0010	+0.0025 +0.0010	+0.0025 +0.0010	+0.0025 +0.0010	+0.0030 +0.0010	+0.0030 +0.0010	+0.0030 +0.0010
Over 2.50 To And Including 3.00						+0.0025 +0.0010	+0.0025 +0.0010	+0.0025 +0.0010	+0.0025 +0.0010	+0.0030 +0.0010	+0.0030 +0.0010	+0.0035 +0.0015
Over 3.00 To And Including 3.50						+0.0030 +0.0010	+0.0030 +0.0010	+0.0030 +0.0010	+0.0030 +0.0010	+0.0035 +0.0010	+0.0035 +0.0010	+0.0040 +0.0015
Over 3.50 To And Including 4.00							+0.0030 +0.0010	+0.0030 +0.0010	+0.0030 +0.0010	+0.0040 +0.0015	+0.0040 +0.0015	+0.0040 +0.0015
Over 4.00 To And Including 4.50								+0.0030 +0.0010	+0.0030 +0.0010	+0.0040 +0.0015	+0.0040 +0.0015	+0.0040 +0.0015
Over 4.50 To And Including 5.00								+0.0030 +0.0010	+0.0030 +0.0010	+0.0040 +0.0015	+0.0040 +0.0015	+0.0040 +0.0015

Table 7 Miscellaneous Pulley Tolerances – Inches (All Sections)

OUTSIDE DIAMETER RANGE	OUTSIDE DIAMETER TOLERANCE	PITCH TO PITCH TOLERANCE	
		ADJACENT GROOVES	ACCUMULATIVE OVER 90 DEGREES
Up Thru 1.000	+0.002 -0.000	±0.001	±0.003
Over 1.000 To And Including 2.000	+0.003 -0.000	±0.001	±0.004
Over 2.000 To And Including 4.000	+0.004 -0.000	±0.001	±0.005
Over 4.000 To And Including 7.000	+0.005 -0.000	±0.001	±0.005
Over 7.000 To And Including 12.000	+0.006 -0.000	±0.001	±0.006
Over 12.000 To And Including 20.000	+0.007 -0.000	±0.001	±0.007
Over 20.000	+0.008 -0.000	±0.001	±0.008

Other Pulley Tolerances

RADIAL RUNOUT*

For outside diameters 8.0 inches and under0.005 inches
 For each additional inch of outside diameter add.....0.0005 inches

AXIAL RUNOUT*

For outside diameters 1.0 inches and under.....0.001 inches
 For each additional inch of outside diameter up through 10.0 inches, add.....0.001 inches
 For each additional inch of outside diameter over 10.0 inches, add.....0.0005 inches

*Total Indicator Reading



SYNCHRONOUS BELTS

SIZE DESIGNATIONS.

Synchronous Belt sizes are identified by a standard number. The first digits specify the belt length to one-tenth inch followed by the belt section (pitch) designation. The digits following the belt section designation represent the nominal belt width times 100. For example, an L section belt 30.000 inches in pitch length and 0.75 inches in width would be specified as a 300L075 Synchronous Belt. The nomenclature for double-sided belts will be the same as for single-sided belts with the addition of the prefix “D” in front of the belt section – Example 300DL075.

STANDARD SECTIONS.

Belt sections are specified in terms of “pitch”. Table 8 gives the Standard Belt Sections and their corresponding “pitch”

NOMINAL TOOTH DIMENSIONS.

Table 9 and Figure 7 show the nominal tooth dimensions for each of the standard belt sections. The tooth dimensions for double-sided belts are identical to those of a single-sided belt.

PITCH LENGTHS.

Standard belt pitch lengths, belt length designations and numbers of teeth are shown in Table 10.

WIDTHS.

Standard belt widths and width designations are shown in Table 11.

Table 8 Standard Belt Sections Inches (See Figure 7)

BELT SELECTION	PITCH	h_g	h_d
MXL	0.080	0.045	
XL	0.200	0.090	
L	0.375	0.14	
DXL	0.200	0.120	0.120
DL	0.375	0.180	0.180

Table 9 Nominal Tooth Dimensions Inches (See Figure 7)

BELT SELECTION	SS TOOTH ANGLE (DEGREES)	h_t	b_t	r_a	r_r
MXL (0.080)	40	0.020	0.045	0.005	0.005
XL (0.200)	50	0.050	0.101	0.015	0.015
L (0.375)	40	0.075	0.183	0.020	0.020
DXL (0.200)	40	0.050	0.101	0.015	0.015
DL (0.375)	40	0.075	0.183	0.020	0.020

Figure 7 Tooth Dimensions

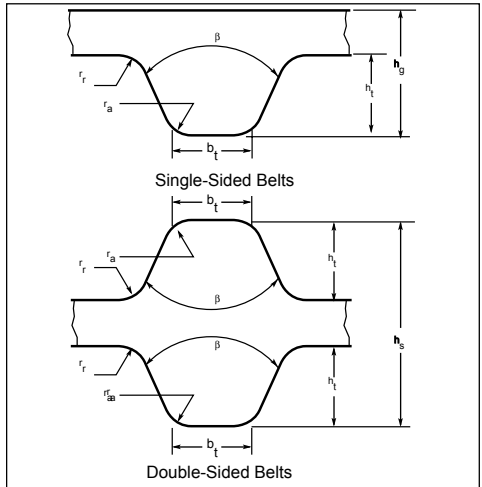

Table 10 Standard Pitch Lengths and Tolerances – Inches

BELT LENGTH DESIGNATION	PITCH LENGTH	PERMISSIBLE DEVIATION FROM STANDARD LENGTH	NUMBER OF TEETH FOR STANDARD LENGTHS		
			MXL (0.080)	XL (0.200)	L (0.375)
36	3.600	±0.016	45		
40	4.000	±0.016	50		
44	4.400	±0.016	55		
48	4.800	±0.016	60		
56	5.600	±0.016	70		
60	6.000	±0.016	75	30	
64	6.400	±0.016	80		
70	7.000	±0.016		35	
72	7.200	±0.016	90		
80	8.000	±0.016	100	40	
88	8.800	±0.016	110		
90	9.000	±0.016		45	
100	10.000	±0.016	125	50	
110	11.000	±0.018		55	
112	11.200	±0.018	140		
120	12.000	±0.018		60	
124	12.375	±0.018			33
124	12.400	±0.018	155		
130	13.000	±0.018		65	
140	14.000	±0.018	175	70	
150	15.000	±0.018		75	40
160	16.000	±0.020	200	80	
170	17.000	±0.020		85	
180	18.000	±0.020	225	90	
187	18.750	±0.020			50
190	19.000	±0.020		95	
200	20.000	±0.020	250	100	
210	21.000	±0.024		105	56
220	22.000	±0.024		110	
225	22.500	±0.024			60
230	23.000	±0.024		115	
240	24.000	±0.024		120	64
250	25.000	±0.024		125	
255	25.500	±0.024			68
260	26.000	±0.024		130	
270	27.000	±0.024			72
285	28.500	±0.024			76
300	30.000	±0.024			80
322	32.250	±0.026			86
345	34.500	±0.026			92
367	36.750	±0.026			98
390	39.000	±0.026			104
420	42.000	±0.030			112
450	45.000	±0.030			120
480	48.000	±0.030			128
510	51.000	±0.032			136
540	54.000	±0.032			144
570	57.000	±0.032			160



York can supply modified stock pulleys or complete specials upon request
 email: support@york-ind.com web: www.york-ind.com

SYNCHRONOUS BELTS (CONT'D)

LENGTH TOLERANCES.

The belt length tolerances shown in Table 10 apply to all belt sections and represent the total manufacturing tolerance on the belt length. For fixed center drives consult the belt manufacturer.

WIDTH TOLERANCE.

Belt width tolerances for all belt sections are given in Table 11.

LENGTH DETERMINATION.

The pitch length of a belt shall be determined by placing the belt on a measuring fixture comprising two pulleys of equal diameter, a method of applying force and a means of measuring the center distance between the two pulleys.

One of the two pulleys is fixed in position while the other is movable along a graduated scale. Recommended measuring pulley dimensions are shown in Table 12.

The fixture is shown schematically in Figure 9. Any pair of equal diameter pulleys of the proper pitch and manufactured to the specifications shown in the "Synchronous Belt Pulleys" section may be used for measuring provided the clearance between the theoretical belt tooth width and the groove width of the measuring pulley is not less than the minimum values shown in Table 12. Measuring forces for the standard belt sections and widths are shown in Table 13.

In measuring the length of a belt, the belt should be rotated at least two revolutions of the belt in order to (a) seat the belt properly in the pulley grooves, (b) divide equally the total force between the two strands of the belt, and (c) determine the midpoint of the center distance travel of the movable pulley which shall define the center distance.

The pitch length shall be calculated by adding the pitch circumference of one of the measuring pulleys to twice the measured center distance between the two pulleys.

Table 11 Standard Belt Widths and Tolerances – Inches

BELT SELECTION	STANDARD BELT WIDTHS		TOLERANCES ON WIDTH FOR BELT PITCH LENGTHS	
	DESIGNATION	DEMENSIONS	UP TO AND INCLUDING 33 INCHES	OVER 33 INCHES UP TO AND INCLUDING 66 INCHES
MXL (0.080)	012	0.12	+0.02	-
	019	0.19	-0.03	
	025	0.25		
XL (0.200)	025	0.25	+0.02	-
	037	0.38	-0.03	
L (0.375)	050	0.50	+0.03	+0.03
	075	0.75	-0.03	-0.05
	100	1.00		

Figure 8 Measuring Pulley & Belt

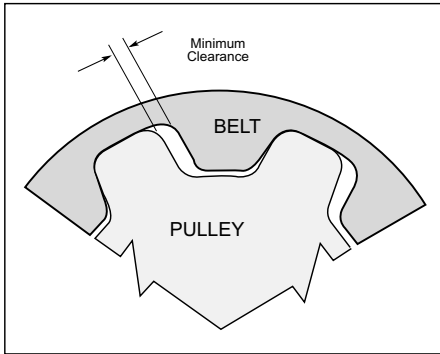

Figure 9 Measuring Pitch Length

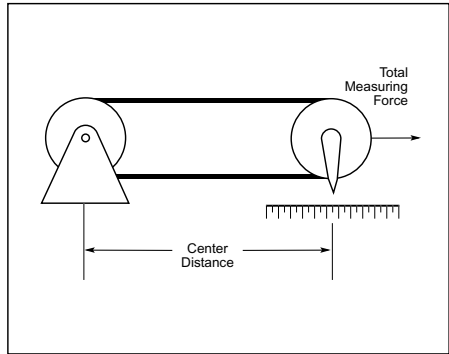

Table 12 Belt Length Measuring Pulleys – Inches

BELT SELECTION	NUMBER OF TEETH	PITCH CIRCUMFERENCE	OUTSIDE DIAMETER	RADIAL RUNOUT T.I.R.*	AXIAL RUNOUT T.I.R.*	MINIMUM CLEARANCE (SEE FIG. 8)
MXL (0.080)	20	1.600	0.4893 ±0.0005	0.0005	0.001	0.010
XL (0.200)	10	2.000	0.6166 ±0.0005	0.0005	0.001	0.012
L (0.375)	16	6.000	1.8799 ±0.0005	0.0005	0.001	0.013

* Total Indicator Reading (Maximum)

Table 13 Total Measuring Force – Pounds Force (lbf)

BELT SELECTION	BELT WIDTH (INCHES)						
	0.12	0.19	0.25	0.38	0.50	0.75	1.00
MXL (0.080)	3	4.5	6				
XL (0.200)			8	12			
L (0.375)					24	40	55



York can supply modified stock pulleys or complete specials upon request
 email: support@york-ind.com web: www.york-ind.com

Table 14 Suggested Service Factors For Synchronous Belt Drives)

TYPES OF DRIVEN MACHINES	TYPES OF DRIVING UNITS					
	AC Motors; Normal Torque, Squirrel Cage, Synchronous & Split Phase. DC Motors; Shunt Wound, Multiple Cylinder Internal Combustion Engines.			AC Motors; High Torque, High Slip, Repulsion - Induction, Single Phase Series Wound & Slip Ring, DC Motors; Series Wound & Compound Wound, Single Cylinder Internal Combustion Engines. Line Shafts. Clutches.		
	Service (3-5 Hours Daily or Seasonal)	Normal Service (8-10 Hours Daily)	Continuous Service (16-24 Hours Daily)	Intermittant Service (3-5 Hours Daily or Seasonal)	Normal Service (8-10 Hours Daily)	Continuous Service (16-24 Hours Daily)
Display Equipment Dispensing Equipment Instrumentation Projection Equipment Measuring Devices Medical Equipment	1.0	1.2	1.4	1.2	1.4	1.6
Appliances, Sweepers, Sewing Machines Office Equipment Wood Lathes, Band Saws	1.2	1.4	1.6	1.4	1.6	1.8
Conveyors: Belt, Light Package, Oven, Screens, Drums, Conical	1.3	1.5	1.7	1.5	1.7	1.9 ¹
Agitators for Liquids Dough Mixers Drill Press, Lathes, Screw Machines, Jointers, Circular Saws, Planers Laundry Machinery Paper Machinery (except pulpers) Printing Machinery	1.4	1.6	1.8	1.6	1.8	2.0
Agitators for semi - liquids Brick Machinery (except Pug Mills) Conveyor Belt: ore coal, sand Line Shafts Machine Tools: Grinder, Shaper, Boring Mill, Milling Machines Pumps: centrifugal, gear, rotary pipeline Screens: vibrating cam type Textile: warpers, reels Compressor: centrifugal	1.5	1.7	1.9	1.7	1.9	2.1
Conveyor: apron, pan, bucket, elevator Extractors, Washers Fans, Blowers; centrifugal, induced draft exhausters Generators & Exciters Hoists, Elevators Rubber Calender, Mills, Extruders Saw Mill Machinery Textile Machinery: looms, spinning frames, twistlers	1.6	1.8	2.0	1.8	2.0	2.2
Centrifuges Conveyors: flight, screw Hammer Mills Paper Pulpers	1.7	1.9	2.1	1.9	2.1	2.3
Brick & Clay Pug Mills Fans, Blowers, Propeller Mine Fans, Positive Blowers	1.8	2.0	2.2	2.0	2.2	2.4

Belt Profile and Pitch Selection

A belt 'profile' refers to the shape of the belt tooth when viewed from the side, just like a 'profile' portrait of a person. This two dimensional view will show the belt in a flat position and not curved around a pulley. The shape of the teeth, including how they blend into the belt and the thickness of the belt itself, are all part of the profile. When individual teeth are attached to a belt, the distance from tooth to tooth is the 'pitch' of the belt. For example, a 2 mm GT2 belt will have a tooth every 2 millimeters and each tooth has a GT2 profile.

The pulley that a belt mates with needs to have the same profile and pitch as the belt itself. Pulley profiles are generally mirror images (inverses) of the belt profile since they must mate together. But the pulley version of the profile will have small modifications to ease the plastic belt's entry and exit into the metal grooves of the pulley.

There are two general types of belt profiles, trapezoidal and curvilinear. Older belt profiles were defined and approved by the Mechanical Power Transmission Association in the mid Twentieth Century and are still industry standards today. These are trapezoidal in shape and are heavily used in the power transmission industry since they are standards that have been in use for decades. The other types of profiles are curvilinear and these tend to be proprietary designs. Curvilinear profiles take advantage of advances in machine tools and computers to optimize the profiles beyond those of trapezoidal designs. Curvilinear profiles generally provide increased horsepower, decreased noise, and reduced tooth wear. Whatever belt profile and pitch is used, the pulley must also use the mating version of the same profile at the same pitch.

Choosing a profile for a synchronous drive design is not only determined by horsepower.

Modern belts with fiberglass, polyester and Kevlar cord can generally handle far more horsepower than the drive system requires. And they are strong enough that belt breakage is rarely seen but rather 'cogging' where a belt will hop over one or more teeth on one of the pulleys rather than engage. This is solved with either a wider belt of the same profile or a profile that can provide more horsepower for the same belt width. It can also be solved by changing the pitch since the greater the pitch, the larger the tooth and the more load each tooth can carry. For example, in moving from a 2 mm pitch to a 3 mm pitch, while the space between teeth increases only 50%, the load carrying capacity of each tooth can increase from 6 to 10 times since the cross sectional area and load bearing surface increases dramatically. The trade-off is that you need enough teeth in mesh with the pulleys to prevent cogging or skipping of the belt under load. So for equivalent loads, smaller pulley diameters require smaller pitches while larger pitches can be used if you have the available real estate in your design to handle larger diameter pulleys. The presence of cogging indicates that there is a problem with the drive system. The order to troubleshoot a cogging system would be:

- Is the belt properly installed and tensioned?
- Are the teeth in mesh adequate for the load?
- Is there a large shock load present or is it a reversing drive? (these conditions are the most demanding on a drive system)
- Finally, is the belt pitch and belt width adequate for the load on the system?

The last three solutions require changes to the design while the first solution (proper tension and installation) is a training and installation issue.



So since belt horsepower capacity isn't generally the limiting factor, the consideration is often what profiles are being used by the suppliers of available components or profiles that your company already has parts in inventory to support. For example, if you need a particularly long belt, you would want to try to find one that was a stock product to avoid a custom tooling charge and whatever profile that length was available in would then become the profile for your design. Or if you have special needs such as low noise or low tooth wear, you would look at curvilinear profiles rather than trapezoidal ones. The following charts show the rated torque for a number of belt profiles across various speed and horsepower settings for the same timing pulley diameters and belt widths. In this apples-to-apples comparison, you can see that there is generally a wide overlap among belt profiles in their ability to handle equivalent loads, especially at lower speeds and power.

When you do choose a profile you can get specific engineering data for your particular application and belt profiles using a computer design tool such as York Industries' free DriveWorks software.

This tool provides data such as static tension on the belt, belt deflection, teeth in mesh, and percent of actual load to design load that the specific drive design you have chosen actually delivers. This is ideal for design files required by ISO-9001 or FDA requirements since the software prints out all the information in a format that documents the specific system parameters in a way that allows easy comparison between different profiles or designs and then serves as documentation for why the final design was chosen. It is also an excellent way to avoid grossly overdesigning the drive system, which is easy to do given the capabilities of today's belts and the time and difficulty of manually calculating what DriveWorks can provide in seconds.

In summary, profile and pitch selection is a tradeoff between what component manufacturers offer on their products that you have to include in your design, parts that your company might already stock or have experience with, and the power transmission and space requirements of your design. The wide overlap in load carrying capacity between profiles and pitches generally provides multiple pitch and profile options for the drive designer.

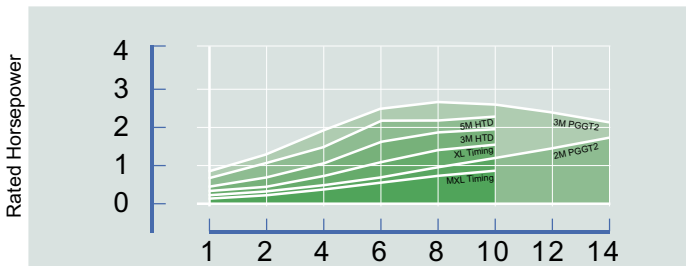

Speed (x 1000rpm) of Fastest Shaft

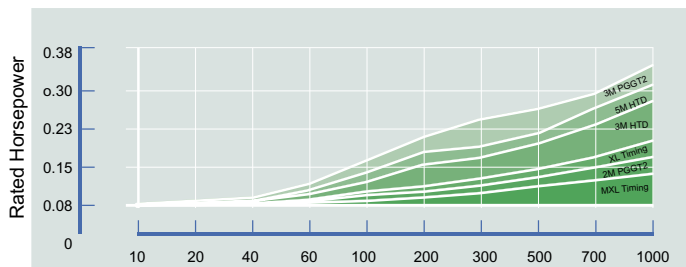

Speed (rpm) of Fastest Shaft

HORSEPOWER AND TORQUE RATING FORMULAS

TORQUE RATINGS.

It is customary to use torque load requirements rather than horsepower load when designing drives using the small pitch MXL section belts. Torque ratings are shown in Table 18 for each standard belt width. Since these belts operate on small diameters resulting in relatively low belt speeds, torque is essentially constant for all rpms. These ratings are based on the adjacent formulas:

TEETH IN MESH FACTOR.

The horsepower or torque ratings from Tables 18, 19, and 20 must be corrected for excessive tooth loading if there are less than 6 teeth in mesh between the belt and the pulley. Determine the proper factor K_z from the following Table 15 to correct for teeth in mesh.

NOMINAL TOOTH DIMENSIONS.

Table 9 and Figure 7 show the nominal tooth dimensions for each of the standard belt sections. The tooth dimensions for double-sided belts are identical to those of a single-sided belt.

HORSEPOWER RATINGS.

Horsepower ratings are used for belt sections MXL, XL and L. These ratings are for the widest standard belt*. To obtain the horsepower rating for other belt widths, multiply the horsepower rating by the appropriate factor shown in Table 16. The horsepower ratings (Tables 18, 19, and 20) are based on the following formulas:

*Total horsepower ratings for double-sided belts are the same as single-sided belts. Contact York Engineering for percent of horsepower available for each side of the belt.

Torque Rating Formulas

BELT SELECTION	BELT WIDTH, INCHES	FORMULA
MXL (0.080)	0.12	$Q_r = d (1.13 - 1.38 \times 10^3 d^2)$
	0.19	$Q_r = d (1.88 - 2.30 \times 10^3 d^2)$
	0.25	$Q_r = d (2.63 - 3.21 \times 10^3 d^2)$

where: Q_r = The maximum torque rating (lbf-inches) for a belt of specified width having six or more teeth in mesh and a pulley surface speed of 6500 feet/minute or less.

Torque ratings for drives with less than six teeth in mesh must be corrected as shown in Table 15, Teeth in Mesh Factor.

d = Pitch diameter of smaller pulley, inches.

Table 15 Teeth in Mesh Factor

TEETH IN MESH	FACTOR K_z
6 or more	1.00
5	0.80
4	0.60
3	0.40
2	0.20

The teeth in mesh may be calculated with the following formula:

$$\text{Teeth in Mesh} = [0.5 - (D-d/6C)]z_1$$

where D = pitch diameter, large pulley, inches

d = pitch diameter, small pulley, inches

C = center distance between shafts, inches

z_1 = number of grooves in small pulley



FINDING THE REQUIRED BELT WIDTH

Caution: Belt width should not exceed pulley diameter or excessive side thrust will result.

Horsepower Rating Formulas

BELT SELECTION	BELT WIDTH, INCHES	FORMULAS
XL (0.200)	0.38	$Pr = dr [0.0916 - 7.07 \times 10^{-5} (dr)^2]$
L (0.375)	1.00	$Pr = dr [0.436 - 3.01 \times 10^{-4} (dr)^2]$

where: Pr = The maximum horsepower rating recommended for the specified standard belt width having six or more teeth in mesh and a pulley surface speed of 6500 feet/minute or less.

Horsepower ratings for drives with less than six teeth in mesh must be corrected as shown in Table 15. Teeth in Mesh Factor.

d = Pitch diameter of smaller pulley, inches.

r = rpm of faster shaft divided by 1000.

*Total horsepower ratings for double-sided belts are the same as single-sided belts. Contact individual manufacturers for percent of horsepower available for each side of the belt.

The tables of torque and horsepower ratings can be used to find the belt width required for a given application. Use the following procedures for each type of rating method.

TORQUE RATING METHOD. (MXL SECTION)

Determine the required belt width as follows:

-Divide the design torque by the teeth in mesh factor to obtain the corrected design torque.

-Compare the corrected design torque with the torque ratings given in Table 18 for the pulley diameter being considered. Select the narrowest belt width which has a torque rating equal to or greater than the corrected design torque.

HORSEPOWER RATING METHOD (XL and L SECTIONS)

Determine the required belt width as follows:

- Multiply the horsepower rating for the widest standard belt of the section you have selected by the teeth in mesh factor to obtain the corrected horsepower rating. The horsepower ratings are given in Tables 19 and 20.

-Divide the design horsepower by the corrected horsepower rating to obtain the required belt width factor.

-Compare the required belt width factor with those shown in Table 16. Select the narrowest belt width which has a width factor equal to or greater than the required belt width factor.

MAXIMUM PULLEY SURFACE SPEED.

Synchronous Belt Drives are designed to operate at pulley surface speeds up to 6500 feet per minute. Special drives are required for operation in excess of 6500 feet per minute. Where vibration is a critical factor, dynamic balancing of pulleys is recommended regardless of the operating speed.

MINIMUM PULLEY SIZE

The recommended minimum pulley size depends on the rpm of the faster shaft. Table 17 gives the minimum number of grooves for common electric motor speeds.

SELECTION OF FLANGED PULLEYS.

To determine when to use flanged pulleys the following conditions should be considered:

1. On all two pulley drives the minimum flanging requirements are two flanges on one pulley, or one flange on each pulley on opposite sides.
2. On drives where the center distance is more than eight times the diameter of the small pulley, both pulleys should be flanged on both sides.
3. On vertical shaft drives, one pulley should be flanged on both sides and all other pulleys in the system should be flanged on the bottom side only.
4. On drives with more than two pulleys, the minimum flanging requirements are two flanges on every other pulley, or one flange on every pulley, alternating sides around the system.

RECOMMENDED USE OF IDLERS.

The use of idlers should be restricted to those cases in which they are functionally necessary. The usual cases are:

- (a) As a means of applying tension when centers are not adjustable.
- (b) To increase the number of teeth in mesh on the small pulley of relatively high ratio drives.

Idlers should be located on the slack side of the belt. For inside idlers, grooved pulleys are recommended up to 40 grooves. On larger diameters, flat, uncrowned pulleys may be used. Outside idlers should be flat, uncrowned pulleys. Idler diameters should not be smaller than the smallest pulley diameter in the system and idler arc of contact should be held to a minimum.

Fixed idlers are recommended.

Table 16 Belt Width Factor

BELT SELECTION	BELT WIDTH (INCHES)						
	0.12	0.19	0.25	0.38	0.50	0.75	1.00
MXL (0.080)	0.43	0.73	1.00				
XL (0.200)			0.62	1.00			
L (0.375)					0.45	0.72	1.00

Table 17 Minimum Number of Grooves

RPM OF FASTER SHAFT	BELT SECTION AND PITCH, INCHES		
	MXL (0.080)	XL (0.200)	L (0.375)
3450	16	12	16
1750	14	12	14
1160	12	10	12
870	--	10	12

No increase in belt width will correct the adverse effects of using sub-minimum pulleys.

Figure 11 Inside & Outside Idlers

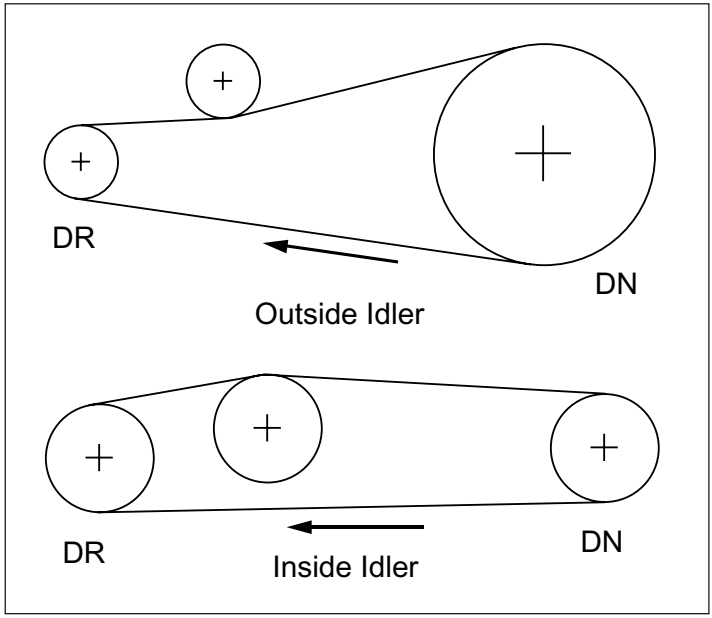

CENTER DISTANCE AND BELT LENGTH

The relationship between center distance and belt pitch length is given by the following formula:

$$L_p = 2C \cos \theta + \frac{\pi (D+d)}{2} + \frac{\pi \theta (D-d)}{180}$$

- where: L_p = pitch length of belt, inches
- C = center distance, inches
- D = pitch diameter of large pulley, inches
- d = pitch diameter of small pulley, inches
- θ = $\sin^{-1} (D-d/2C)$, degrees

The approximate center distance can be found by this formula:

$$C = \frac{K + \sqrt{K^2 - 32 (D-d)^2}}{16}$$

where: $K = 4L - 6.28 (D+d)$

The exact center distance can then be determined by trial, using the belt pitch length formula, or use center distance tables available from belt manufacturers.

Design software such as York Industries free DriveWorks program, can also be used to easily provide exact center distances and belt lengths.

The pitch length increment of a synchronous belt is equal to some multiple of the pitch of the belt. For example, the belt length increment of XL section (0.200 pitch) must be 0.200, 0.400, 0.600, etc.

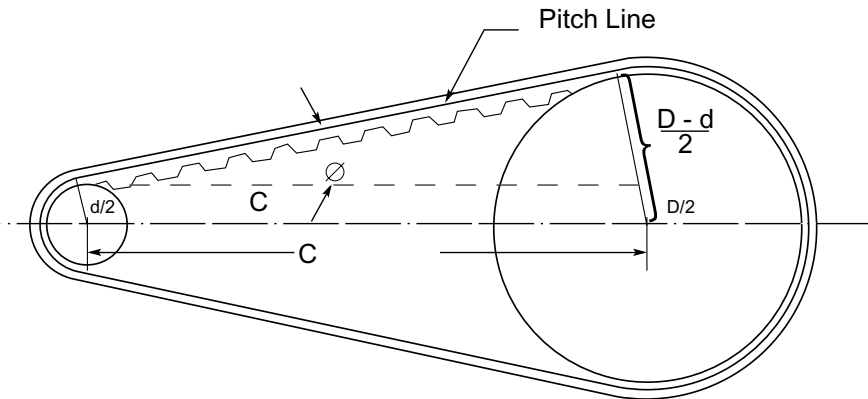

Table 18 Torque rating for MXL section (0.080 inch pitch)

BELT WIDTH, INCHES	RATED TORQUE (IBF-INCH) FOR SMALL PULLEY (NUMBER OF GROOVES AND PITCH DIAMETER, INCHES)									
	10MXL 0.255	12MXL 0.306	14MXL 0.357	16MXL 0.407	18MXL 0.458	20MXL 0.509	22MXL 0.560	24MXL 0.611	28MXL 0.713	30MXL 0.764
0.12	0.29	0.35	0.40	0.46	0.52	0.57	0.63	0.69	0.81	0.86
0.19	0.48	0.58	0.67	0.77	0.86	0.96	1.05	1.15	1.34	1.44
0.25	0.67	0.80	0.94	1.07	1.20	1.34	1.47	1.61	1.87	2.01

Table 19 Horsepower rating for .38 inch wide XL Section Belt (0.200 inch pitch)

RPM of Faster Shaft	RATED HORSEPOWER FOR SMALL PULLEY (NUMBER OF GROOVES AND PITCH DIAMETER)									
	10XL	12XL	14XL	16XL	18XL	20XL	22XL	24XL	28XL	30XL
	0.637	0.764	0.891	1.019	1.146	1.273	1.401	1.528	1.783	1.910
950	0.055	0.066	0.077	0.089	0.10	0.11	0.12	0.13	0.15	0.17
1160	0.068	0.081	0.095	0.11	0.12	0.14	0.15	0.16	0.19	0.20
1425	0.083	0.10	0.12	0.13	0.15	0.17	0.18	0.20	0.23	0.25
1750	0.10	0.12	0.14	0.16	0.18	0.20	0.22	0.24	0.28	0.30
2850	0.17	0.20	0.23	0.26	0.30	0.33	0.36	0.39	0.46	0.49
3450	0.20	0.24	0.28	0.32	0.36	0.40	0.43	0.47	0.55	0.58
100	0.006	0.007	0.008	0.009	0.010	0.012	0.013	0.014	0.016	0.017
200	0.012	0.014	0.016	0.019	0.021	0.023	0.026	0.028	0.033	0.035
300	0.018	0.021	0.024	0.028	0.031	0.035	0.038	0.042	0.049	0.052
400	0.023	0.028	0.033	0.037	0.042	0.047	0.051	0.056	0.065	0.070
500	0.029	0.035	0.041	0.047	0.052	0.058	0.064	0.070	0.082	0.087
600	0.035	0.042	0.049	0.056	0.063	0.070	0.077	0.084	0.098	0.10
700	0.041	0.049	0.057	0.065	0.073	0.082	0.090	0.098	0.11	0.12
800	0.047	0.056	0.065	0.075	0.084	0.093	0.10	0.11	0.13	0.14
900	0.053	0.063	0.073	0.084	0.094	0.10	0.12	0.13	0.15	0.16
1000	0.058	0.070	0.082	0.093	0.10	0.12	0.13	0.14	0.16	0.17
1100	0.064	0.077	0.090	0.10	0.12	0.13	0.14	0.15	0.18	0.19
1200	0.070	0.084	0.098	0.11	0.13	0.14	0.15	0.17	0.20	0.21
1300	0.076	0.091	0.11	0.12	0.14	0.05	0.17	0.18	0.21	0.23
1400	0.082	0.098	0.11	0.13	0.15	0.16	0.18	0.20	0.23	0.24
1500	0.087	0.10	0.12	0.14	0.16	0.17	0.19	0.21	0.24	0.26
1600	0.093	0.11	0.13	0.15	0.17	0.19	0.20	0.22	0.26	0.28
1700	0.099	0.12	0.14	0.16	0.18	0.20	0.22	0.24	0.28	0.30
1800	0.10	0.13	0.15	0.17	0.19	0.21	0.23	0.25	0.29	0.31
2000	0.12	0.14	0.16	0.19	0.21	0.23	0.26	0.28	0.32	0.35
2200	0.13	0.15	0.18	0.20	0.23	0.25	0.28	0.31	0.36	0.38
2400	0.14	0.17	0.20	0.22	0.25	0.28	0.31	0.33	0.39	0.41
2600	0.15	0.18	0.21	0.24	0.27	0.30	0.33	0.36	0.42	0.45
2800	0.16	0.20	0.23	0.26	0.29	0.32	0.36	0.39	0.45	0.48
3000	0.17	0.21	0.24	0.28	0.31	0.35	0.38	0.41	0.48	0.51
3200	0.19	0.22	0.26	0.30	0.33	0.37	0.40	0.44	0.51	0.54
3400	0.20	0.24	0.28	0.31	0.35	0.39	0.43	0.47	0.54	0.58
3600	0.21	0.25	0.29	0.33	0.37	0.41	0.45	0.49	1.57	0.61
3800	0.22	0.26	0.31	0.35	0.39	0.44	0.48	0.52	0.60	0.64
4000	0.23	0.28	0.32	0.37	0.41	0.46	0.50	0.54	0.63	0.67
4200	0.24	0.29	0.34	0.39	0.43	0.48	0.52	0.57	0.66	0.70
4400	0.26	0.31	0.35	0.40	0.45	0.50	0.55	0.59	0.68	0.73
4600	0.27	0.32	0.37	0.42	0.47	0.52	0.57	0.62	0.71	0.76
4800	0.28	0.33	0.39	0.44	0.49	0.54	0.59	0.64	0.74	0.79
5000	0.29	0.35	0.40	0.46	0.51	0.56	0.62	0.67	0.77	0.81
5500				0.50	0.56	0.62	0.67	0.73	0.83	0.88
6000				0.54	0.61	0.67	0.73	0.79	0.89	0.94
6500				0.59	0.65	0.72	0.78	0.84	0.95	1.00
7000				0.63	0.70	0.77	0.83	0.89	1.01	1.06
7500				0.67	0.74	0.81	0.88	0.94	1.06	1.10
8000					0.79	0.86	0.93	0.99	1.10	1.15
8500					0.83	0.90	0.97	1.03	1.14	1.18
9000					0.87	0.94	1.01	1.08	1.18	1.22
9500					0.91	0.98	1.05	1.11	1.21	1.24
10000					0.94	1.02	1.09	1.15	1.23	1.26

This pulley and rpm can be used only if a corresponding reduction in belt service life is allowable.



York can supply modified stock pulleys or complete specials upon request
 email: support@york-ind.com web: www.york-ind.com

Table 20 Horsepower rating for 1.00 inch wide L section belt (0.375 inch pitch)

RPM of Faster Shaft	RATED HORSEPOWER FOR SMALL PULLEY (NUMBER OF GROOVES AND PITCH DIAMETER)															
	10L	12L	14L	15L	18L	20L	22L	24L	26L	28L	30L	32L	36L	40L	44L	48L
	1.194	1.432	1.671	1.910	2.149	2.387	2.628	2.865	3.104	3.342	3.581	3.820	4.297	4.775	5.252	5.730
725	0.38	0.45	0.53	0.60	0.68	0.75	0.83	0.90	0.98	1.05	1.13	1.20	1.35	1.50	1.64	1.79
870	0.45	0.54	0.63	0.72	0.81	0.90	0.99	1.08	1.17	1.26	1.35	1.44	1.61	1.79	1.96	2.14
950	0.49	0.59	0.69	0.79	0.89	0.99	1.08	1.18	1.28	1.37	1.47	1.57	1.76	1.95	2.14	2.32
1160	0.60	0.72	0.84	0.96	1.08	1.20	1.32	1.44	1.56	1.67	1.79	1.91	2.14	2.36	2.59	2.81
1425	0.74	0.89	1.03	1.18	1.33	1.47	1.62	1.76	1.90	2.04	2.18	2.32	2.60	2.87	3.14	3.40
1750	0.91	1.09	1.27	1.45	1.62	1.80	1.97	2.15	2.32	2.49	2.66	2.82	3.15	3.47	3.77	4.07
2850		1.76	2.04	2.32	2.60	2.87	3.14	3.40	3.65	3.89	4.13	4.36	4.79	5.17	5.52	5.81
3450			2.46	2.79	3.11	3.42	3.73	4.02	4.30	4.57	4.82	5.06	5.48	5.84	6.11	6.29
100	0.05	0.06	0.07	0.08	0.09	0.10	0.11	0.12	0.14	0.15	0.16	0.17	0.19	0.21	0.23	0.25
200	0.10	0.12	0.15	0.17	0.19	0.21	0.23	0.25	0.27	0.29	0.31	0.33	0.37	0.42	0.46	0.50
300	0.16	0.19	0.22	0.25	0.28	0.31	0.34	0.37	0.41	0.44	0.47	0.50	0.56	0.62	0.69	0.75
400	0.21	0.25	0.29	0.33	0.37	0.42	0.46	0.50	0.54	0.58	0.62	0.67	0.75	0.83	0.91	1.00
500	0.26	0.31	0.36	0.42	0.47	0.52	0.57	0.62	0.68	0.73	0.78	0.83	0.93	1.04	1.14	1.24
600	0.31	0.37	0.44	0.50	0.56	0.62	0.69	0.75	0.81	0.87	0.93	1.00	1.12	1.24	1.36	1.49
700	0.36	0.44	0.51	0.58	0.65	0.73	0.80	0.87	0.94	1.02	1.09	1.16	1.30	1.45	1.59	1.73
800	0.42	0.50	0.58	0.67	0.75	0.83	0.91	1.00	1.08	1.16	1.24	1.32	1.49	1.65	1.81	1.97
900	0.47	0.56	0.65	0.75	0.84	0.93	1.03	1.12	1.21	1.30	1.40	1.49	1.67	1.85	2.03	2.21
1000	0.52	0.62	0.73	0.83	0.93	1.04	1.14	1.24	1.34	1.45	1.55	1.65	1.85	2.05	2.25	2.44
1100	0.57	0.69	0.80	0.91	1.03	1.14	1.25	1.36	1.48	1.59	1.70	1.81	2.03	2.25	2.46	2.67
1200	0.62	0.75	0.87	1.00	1.12	1.24	1.36	1.49	1.61	1.73	1.85	1.97	2.21	2.44	2.67	2.90
1300	0.63	0.81	0.94	1.08	1.21	1.34	1.48	1.61	1.74	1.87	2.00	2.13	2.38	2.63	2.88	3.12
1400	0.73	0.87	1.02	1.16	1.30	1.45	1.59	1.73	1.87	2.01	2.15	2.29	2.56	2.82	3.09	3.34
1500	0.78	0.93	1.09	1.24	1.40	1.55	1.70	1.85	2.00	2.15	2.30	2.44	2.73	3.01	3.29	3.56
1600	0.83	1.00	1.16	1.32	1.49	1.65	1.81	1.97	2.13	2.29	2.44	2.60	2.90	3.20	3.49	3.77
1700	0.88	1.06	1.23	1.41	1.58	1.75	1.92	2.09	2.26	2.42	2.59	2.75	3.07	3.38	3.68	3.97
1800		1.12	1.30	1.49	1.67	1.85	2.03	2.21	2.38	2.56	2.73	2.90	3.23	3.56	3.87	4.17
1900		1.18	1.37	1.57	1.76	1.95	2.14	2.32	2.51	2.69	2.87	3.05	3.40	3.73	4.05	4.36
2000		1.24	1.45	1.65	1.85	2.05	2.25	2.44	2.63	2.82	3.01	3.20	3.56	3.90	4.23	4.54
2200		1.36	1.59	1.81	2.03	2.25	2.46	2.67	2.88	3.09	3.29	3.49	3.87	4.23	4.57	4.89
2400		1.49	1.73	1.97	2.21	2.44	2.67	2.90	3.12	3.34	3.56	3.77	4.17	4.54	4.89	5.21
2600		1.61	1.87	2.13	2.38	2.63	2.88	3.12	3.36	3.59	3.82	4.04	4.45	4.84	5.19	5.50
2800		1.73	2.01	2.29	2.56	2.82	3.09	3.34	3.59	3.83	4.07	4.30	4.72	5.11	5.45	5.75
3000		1.85	2.15	2.44	2.73	3.01	3.29	3.56	3.82	4.07	4.31	4.54	4.98	5.36	5.69	5.97
3200			2.29	2.60	2.90	3.20	3.49	3.77	4.04	4.29	4.54	4.78	5.21	5.59	5.90	6.14
3400			2.42	2.75	3.07	3.38	3.68	3.97	4.25	4.51	4.77	5.00	5.43	5.79	6.07	6.27
3600			2.56	2.90	3.23	3.56	3.87	4.17	4.45	4.72	4.98	5.21	5.63	5.97	6.21	6.35
3800			2.69	3.05	3.40	3.73	4.05	4.36	4.65	4.92	5.17	5.41	5.81	6.11	6.31	6.39
4000			2.82	3.20	3.56	3.90	4.23	4.54	4.84	5.11	5.36	5.59	5.97	6.23	5.96,37	6.37
4200				3.34	3.71	4.07	4.40	4.72	5.02	5.29	5.53	5.75	6.10	6.32	6.39	6.30
4400				3.49	3.87	4.23	4.57	4.89	5.19	5.45	5.69	5.90	6.21	6.37	6.36	#6.17
4600				3.63	4.02	4.39	4.74	5.06	5.35	5.61	5.84	6.03	6.29	6.39	6.29	#5.98
4800				3.77	4.17	4.54	4.89	5.21	5.50	5.75	5.97	6.14	6.35	6.37	#6.17	#5.73
5000				3.90	4.31	4.69	5.04	5.36	5.64	5.88	6.09	6.23	6.38	6.31	#6.00	#5.41
5200				4.04	4.43	4.84	5.19	5.50	5.77	6.00	6.18	6.30	6.38	6.22	#5.70	#5.03
5400				4.17	4.59	4.98	5.32	5.63	5.89	6.10	6.25	6.35	6.36	6.36	#5.58	#4.57
5600				4.30	4.72	5.11	5.45	5.75	6.00	6.19	6.32	6.38	6.30	#3.90	#5.17	#4.05
5800				4.42	4.85	5.24	5.58	5.86	6.09	6.26	6.36	6.39	6.21	#5.68	#4.77	#3.44
6000				4.54	4.98	5.36	5.69	5.97	6.18	6.32	6.38	6.37	#6.08	#5.41	#4.32	#2.76

This pulley and rpm can be used only if a corresponding reduction in belt service life is allowable.

Pulley Surface speeds over 6500 fpm; special pulleys are required.

Belt Materials And Construction

A timing belt has two main components - the cords that are molded inside it to carry the torque load and the plastic compound used to shape the teeth and cover the cord itself. Both are available in different materials for different types of belts. The end use of the belt is the major factor in determining what materials to use.

The cord is generally made from polyester, fiberglass, or Kevlar and does the work of transmitting the power in the drive system through the belt. It is wound perpendicular to the belt teeth so that it transmits the power applied to the belt in a linear way. The common example of belts that carry large loads are the serpentine belts used in automobile engines. Belts used in smaller drive systems such as York products go into don't have anything approaching the loads in a car engine. But in both cases, elongation (stretch) of the belt is minimal. Especially in small drive applications, belt stretch is practically non-existent since the cord materials are so strong in relation to the loads they are transmitting. Loads that are too high generally result not in cord breakage, but in the belt teeth jumping, or 'cogging' over the pulley teeth.

The plastic used in the molded belt is usually urethane, neoprene, or an engineered polymer with special properties.

The plastic is injected into a mold that already contains the wound cord and has accurate tooth profiles cut into the mold. Each different belt length requires a different mold since the exact number of teeth on the finished belt must also be in the mold to produce a finished, continuous belt with no beginning or end. A mold produces a 'sleeve' that is often 18 to 36 inches wide with the desired number of teeth. Special slitting tools are used to very accurately trim the sleeve into the desired belt widths. Urethane is often used to produce belts for food processing when FDA requirements must be met. Urethane also can be colored or left in a clear or natural state, which means that any particles are less likely to be seen than those from black neoprene belts. Neoprene is generally the standard material for timing belts since it has good wear characteristics and very accurately holds the tooth profile from the mold. York PowerGrip GT2 neoprene belts include a nylon fabric facing to reduce wear. Special requirements for low dust/particle applications such as clean rooms, medical, or even office copiers can be met with engineered polymers. York's TruMotion line of belts uses an EPDM polymer core with a nylon overcoating on all tooth wear surfaces to generate 78% less dust than neoprene while holding the tooth profile more accurately over thousands of hours of use than either neoprene or urethane belts.

Belt Material	Wear (Life)	Temp. Range	Dust	Low Cost	FDA Approved	AntiStatic Available
Neoprene	Better	Good	Good	Best	No	No
Urethane	OK	Better	Better	Better	Some grades	Some grades
Eng. Polymers (TruMotion)	Best	Best	Best	Good	No	No



York can supply modified stock pulleys or complete specials upon request email: support@york-ind.com web: www.york-ind.com

TruMotion Belts

York TruMotion belts use special materials and construction to produce a belt that is optimized for minimal tooth wear. The process of a belt tooth mating with a pulley tooth produces friction as the belt tooth engages and then disengages while the drive system operates. It is the face of the belt tooth that will generate heat and exhibit wear as this occurs. This results in fine dust particles that will, over time, fall from the belt at the disengagement end of the pulley. This dust can be objectionable from a cleanliness standpoint in applications such as electronic clean rooms, medical equipment, or even office products that need a clean, non-marking paper path. This dust is actually a byproduct of the tooth surface wear caused by friction. So TruMotion belts have a special nylon fabric facing on the tooth surfaces that acts to minimize friction and therefore wear during engagement and disengagement with the pulley teeth.

Nylon is a self-lubricating plastic that offers excellent wear characteristics. A common use for nylon is in automobile speedometer gears where there is toothed contact with metal transmission gears and operating lifetimes of hundreds of millions of revolutions are required.

York drive systems don't see those kinds of stresses, but the nylon material on the face of a TruMotion belt insures a precise tooth shape for over four times longer than with standard neoprene or urethane belts. This is important if drive accuracy is critical throughout the life of the drive. And TruMotion achieves this by minimizing wear and dust, providing an exceptionally clean belt.

The TruMotion belt material that surrounds the fiberglass cord is an engineered polymer that also contributes to cleanliness and precision running due to its strength and ability to firmly lock the nylon facing and cord material in place to absolutely minimize relative motion between them as the belt rotates. Yet it provides excellent flex and shock absorption to handle vibrations that occur in drive systems. TruMotion fills a unique niche when a drive design demands cleanliness or precision well beyond what an ordinary neoprene or urethane belt can provide. So if your design specification includes long belt life, high cleanliness requirements, or precision drive timing and alignment, TruMotion can help you achieve all of these.



Tensioners

Tensioners are useful additions to a drive design to deal with issues such as the fit of a belt or center distances between components. The purpose of a tensioner is to take up slack in a belt and maintain the tension of the belt so it doesn't slip against the pulleys while under load. Tensioners allow a designer to use a stock belt that may be slightly longer than what is required rather than pay for tooling a custom belt. Tensioners also adjust for tolerances in a drive system and can make installation and servicing of belts easier. A tensioner used as an idler in a design can enable an engineer to make sharp turns in a belt layout with the tensioner keeping proper tension in the belt and insuring that the belt doesn't slip against a pulley due to the sharp changes in belt direction. Not every drive requires a tensioner, but a tensioner is often useful to improve drive performance in actual use.

There are two basic designs for tensioners. Slotted tensioners move 'in and out' along a straight line, or slot, against the belt. A pivoting tensioner has a fixed pivot point and moves in an arc against the belt. The most common example of a pivoting tensioner is the one used on a car engine to tension the serpentine belt that drives all the accessories. Both types contain an idler at their ends which makes the actual contact with the belt and rotates to keep up with the belt so that there is no relative motion between their surfaces.

Tensioners can be either static (fixed) or dynamic (moving) in operation. A static tensioner means that the tension is set and the tensioner fastened into place to keep that specific tension against the belt during drive system operation. A dynamic tensioner uses some sort of a spring device to provide a known counterforce to push the tensioner into the belt to tension the belt.

The spring used in the tensioner design means the tensioner has the ability to move as the belt tension increases or decreases, making a dynamic tensioner an excellent choice for drives that do not have constant loads.

Tensioners can be placed either inside or outside of the belt, and on any span of a belt drive. It is generally better to place the tensioner on the belt span with the least tension (the slack span on a 2-pt drive). If the tensioner is going to put a lot of deflection on the belt then try to put it on the inside / tooth side of the design, as belts are manufactured to be shaped more easily from the inside, like they would be when going around a pulley. The idlers on inside tensioners should have the same profile as the belt they are pushing against. Outside tensioners are flat like the outside of the belt. They are useful to increase belt wrap around a pulley and are generally quieter, especially on high speed applications. Tensioners or idlers can also be used to change the belt direction and the design layout to get around obstacles that would otherwise interfere with a drive belt. In this case, a tensioner is actually functioning as an idler. By design, an idler has only one fixed position against a belt while a tensioner can be mounted through a range of positions relative to the belt.

Tensioners can be individually designed by a drive engineer or they can be purchased as preassembled components. York Industries has a line of stainless steel, small tensioners ideal for use in small synchronous drive systems. These complete tensioners can be ordered from stock in a number of pulley diameters, profiles, and heights above the mounting surface.

