

SS-3 Static Slot Tensioner

This size Static Slotted Tensioner provides a compact but strong tensioner for designs that have smaller belt widths and tight space constraints. It fits well both inside or outside the belt. It also allows changes in belt direction or increased teeth in mesh in very small areas.

Operating Characteristics

Range of adjustment - .50 inches (12.7 mm)

Maximum force against belt - 2.5 pounds (1.1 kg) continuous, 10 pounds (4.5 kg) peak

* Mounting Data:

- Approximate footprint without pulley of .85 inches (21.2 mm) wide by 1.8 inches (45.7 mm) length
- Minimum clearance from mounting surface to bottom of pulley is .18 inches (4.6 mm) for self lubricating pulley or ball bearings. Plastic sleeve bearings require .21 inches (5.3 mm) minimum clearance.
- Requires one #6-32 threaded hole and one .125 (3.2 mm) by .50 slot. See drawing below.

If needed, mounting spacers are available from York for higher than standard belt clearances.
See www.york-ind.com/spacers or contact York for details.

** Tensioner Height

To determine tensioner maximum height, add total end to end pulley width desired + pulley clearance from mounting surface desired = X

- If X is less than or equal to .637 (16.2mm), tensioner height is 0.652 (16.6 mm)
- If X is greater than .637 (16.2mm), consult York Engineering for available optional shafts and mounting bases.

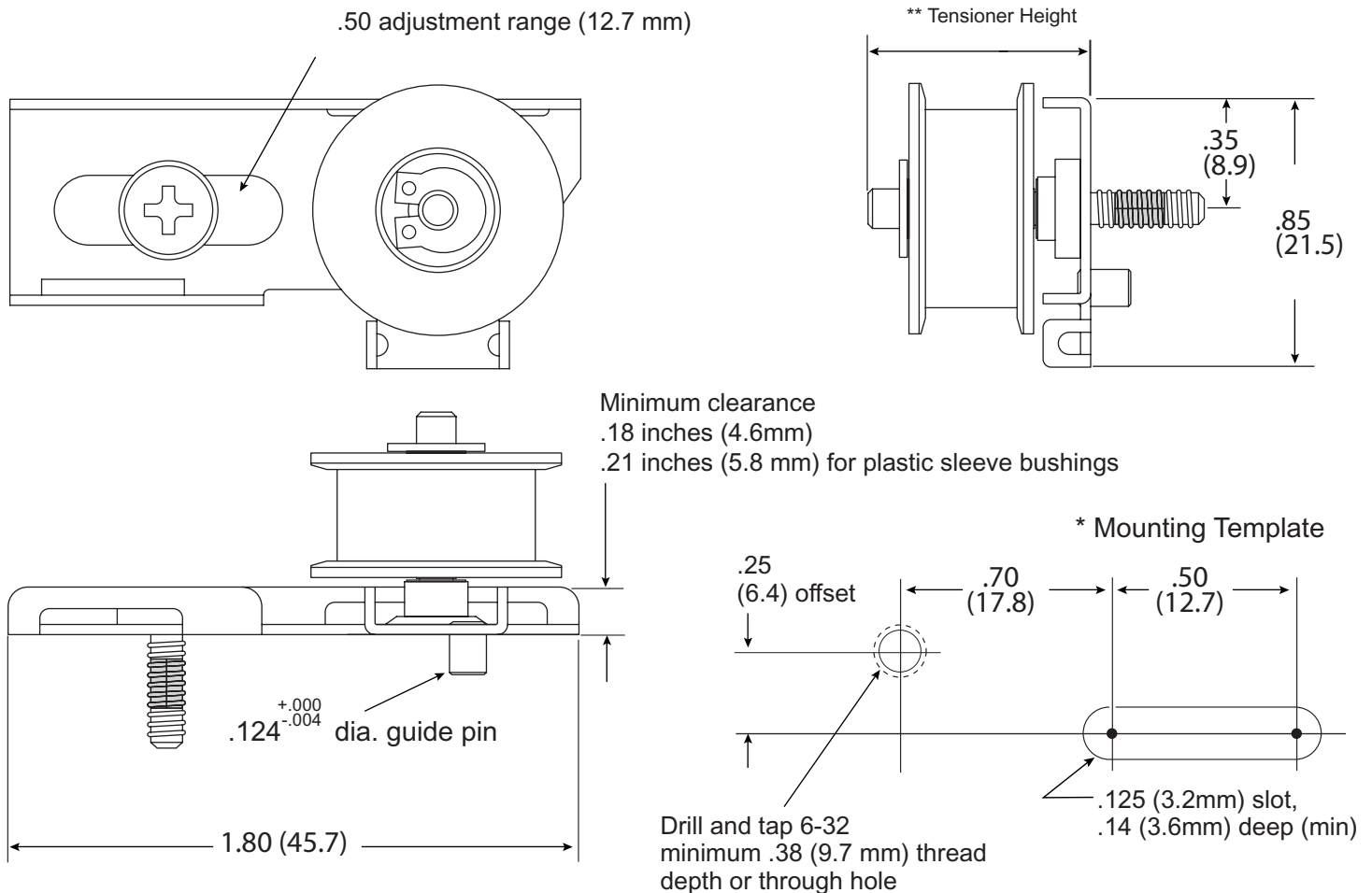

York Industries, Inc.
303 Nassau Boulevard
Garden City Park, NY 11040
Phone: 516-746-3736
(800) 354-8466
Fax: 516-746-3741
www.york-ind.com

SS-3 Static Slot Tensioner (page 2)

All York Size 3 Tensioners Include:

301 stainless steel construction for strength and harsh environments	Designs tested to over one million cycles
Operating temperatures possible from -60°F to +185°F (-51°C to 85°C)	Survives salt spray, dust, and condensing high humidity environments with proper bearings
Choice of idler pulley profiles - flat, 2mm GT, 3mm GT, .080 (MXL) or 3mm HTD	Idler pulleys available with sealed ball bearings, self lubricating plastic sleeves in aluminum pulleys or self lubricating all plastic pulleys
Ease of assembly with self locking, reusable Phillips hardware in 6-32 threads	Idler pulley retaining clip withstands minimum of 10 lbs (4.5 kg) pull force/side force on pulley
Downloadable CAD files for tensioners and pulleys	Dynamic tensioners include reference markings to aid in setting belt tension during assembly and service
Free access to York's engineering staff for answers to design and application questions	Conductive grease (sealed ball bearings) or static dissipative (plastic) to prevent static electricity build-up on belts
Special mounting bushing to aid in setting belt tension.	Idler shafts are 416 stainless steel hardened to Rockwell C 38-42

Operating Environments:

Idler Pulley/Bearing Type	Maximum Operating Temperature	Minimum Operating Temperature	High Dust Environments	High Humidity	Relative Cost	Max Speed in RPM
Aluminum/Ball Bearing	185° F (85°C) - may be limited by belt max temp	-60°F (-51°C)	Yes - Sealed ABEC Bearings With Conductive Grease	Yes	More Expensive	Limited by belt, not bearing
Aluminum/Plastic Self Lubricating Sleeve	185° F (85°C) - may be limited by belt max temp	-40°F (-40°C)	OK in most cases	Yes	Moderate - good for small and medium volumes	Up to 4,500 RPM continuous with up to 9,000 RPM peak.
One Piece Self Lubricating Carbon Filled Polycarbonate UL V94-0 Flammability	180° F (82°C)	20°F - consult York for designs down to -40°F (-40°C)	Generally not for extremely high dust areas	Yes - to 95% but must be non condensing	Least Expensive. Need high volumes if custom mold required	Up to 4,500 RPM continuous with up to 7,000 RPM peak



York Industries, Inc.
 303 Nassau Boulevard
 Garden City Park, NY 11040
 Phone: 516-746-3736
 (800) 354-8466
 Fax: 516-746-3741
www.york-ind.com