

SS-4 Static Slot Tensioner

The Static Slot Tensioner is the classic tensioner design. It works equally well outside or inside the belt, if there is enough room for an inside installation. Plus it can even function as an idler to change the belt direction or increase the teeth in mesh. York offers an engineered, catalog solution to the need for a tensioner in a belt drive system.

Operating Characteristics

Range of adjustment - .80 inches (20mm)

Maximum force against belt - 10 pounds (4.5 kg) continuous, 15 pounds (6.8 kg) peak

* Mounting Data:

- Approximate footprint without idler pulley of .90 inches (22.9mm) wide by 2.6 inches (66.0mm) long
- Minimum clearance from mounting surface to bottom of pulley is .18 inches (5.1mm) except plastic sleeve bearings require .23 inches (5.8 mm) minimum clearance.
- Requires one hole tapped 10-32 or M5 x .8 either through sheetmetal, or blind hole with minimum .38 (9.7mm) thread depth. See drawing below.

**If needed, mounting spacers are available from York for higher than standard belt clearances.
See www.york-ind.com/spacers or contact York for details.**

** Tensioner Height

To find your tensioner height, determine Pulley Width + Belt Clearance desired = X

- If X is less than or equal to .600 (15.2mm), tensioner height is 0.925 (23.5mm)
- If X is between .600 (15.2mm) and .875 (22.2mm), tensioner height is 1.200 (30.5mm)
- If X is larger than .875 (22.2mm), consult York Engineering.

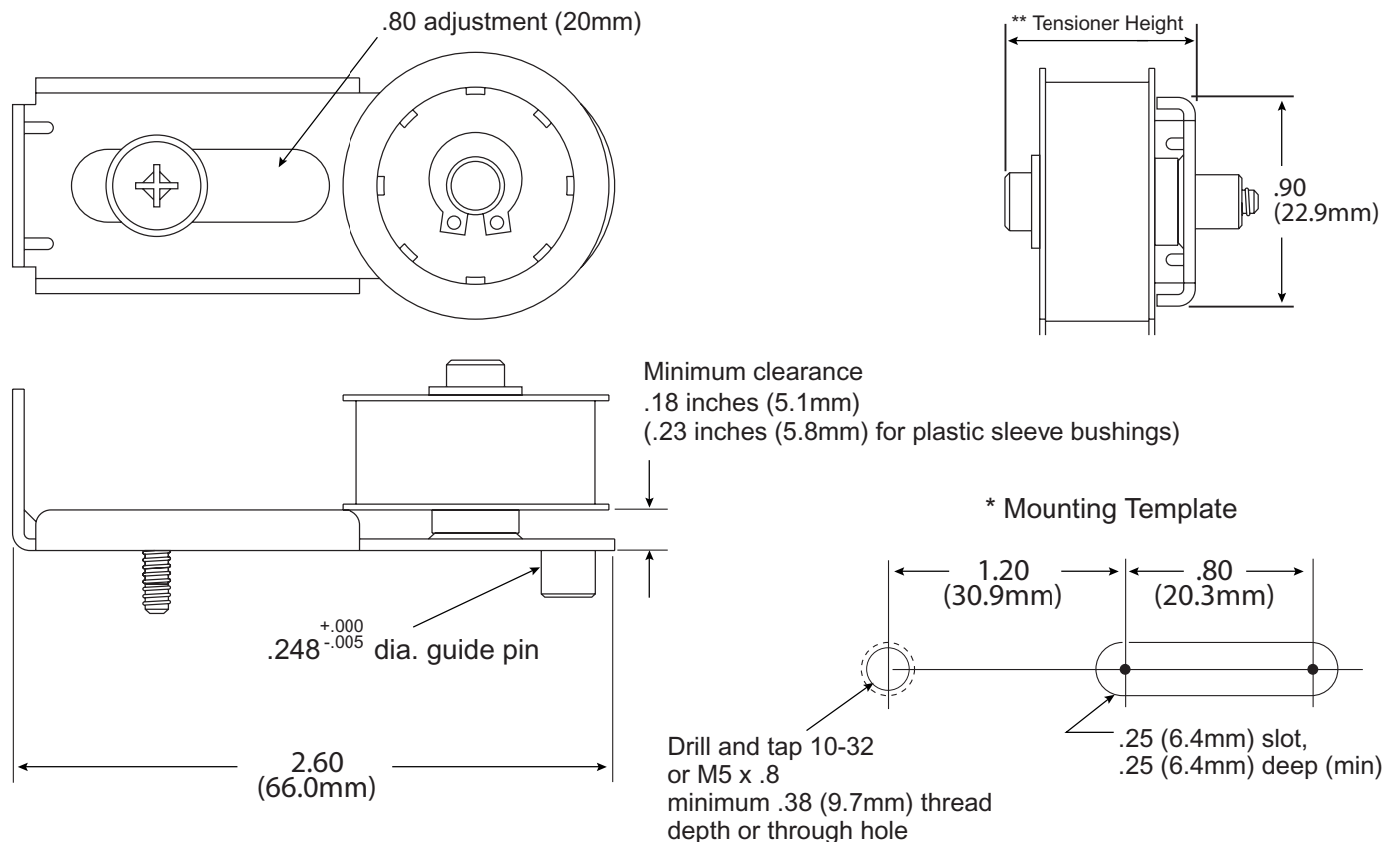

*York Tensioners Are Patent Pending

YORK
INDUSTRIES
An ISO 9001-2000 Company

York Industries, Inc.
303 Nassau Boulevard
Garden City Park, NY 11040
Phone: 516-746-3736
(800) 354-8466
Fax: 516-746-3741
www.york-ind.com

SS-4 Static Slot Tensioner (page 2)

All York Tensioners Include:

301 stainless steel construction for strength and harsh environments	Designs tested to over one million cycles
Operating temperatures possible from -60 F to +185 F (-51 C to 85 C)	Survives salt spray, dust, and condensing high humidity environments with proper bearings
Choice of idler pulley profiles - flat, 2mm GT, 3mm GT MXL, XL, 3mm HTD or 5mm HTD	Idler pulleys available with sealed ball bearings, self lubricating plastic sleeves in aluminum pulleys or self lubricating all plastic pulleys
Ease of assembly with self locking, reusable Phillips hardware in 10-32 or M5 x.8 threads	Idler pulley retaining clip withstands minimum of 15 lbs (6.8 kg) pull force
Downloadable CAD files for tensioners and pulleys	Reference markings to aid in setting belt tensioner during assembly and service
Free access to York's engineering staff for answers to design and application questions	Conductive grease (sealed ball bearings) or static dissipative (plastic) to prevent static electricity build-up on belts
Special mounting bushing to aid in setting belt tension.	Idler shafts are 416 stainless steel hardened to Rockwell C 38-42

Operating Environments:

Idler Pulley/Bearing Type	Maximum Operating Temperature	Minimum Operating Temperature	High Dust Environments	High Humidity	Relative Cost	Max Speed in RPM
Aluminum/Ball Bearing	185°F (85°C) - may be limited by belt max temp	-60°F (-51°C)	Yes - Sealed ABEC Bearings With Conductive Grease	Yes	More Expensive	Limited by belt, not bearing
Aluminum/Plastic Self Lubricating Sleeve	185°F (85°C) - may be limited by belt max temp	-40°F (-40°C)	OK in most cases	Yes	Moderate - good for small and medium volumes	Up to 4,500 RPM continuous with up to 9,000 RPM peak.
One Piece Self Lubricating Carbon Filled Polycarbonate UL V94-0 Flammability	180°F (82°C)	20°F - consult York for designs down to -40°F (-40°C)	Generally not for extremely high dust areas	Yes - to 95% but must be non condensing	Least Expensive. Need high volumes if custom mold required	Up to 4,500 RPM continuous with up to 7,000 RPM peak



INDUSTRIES

An ISO 9001-2000 Company

York Industries, Inc.
 303 Nassau Boulevard
 Garden City Park, NY 11040
 Phone: 516-746-3736
 (800) 354-8466
 Fax: 516-746-3741
 www.york-ind.com